

92L Series

Model 92L650C

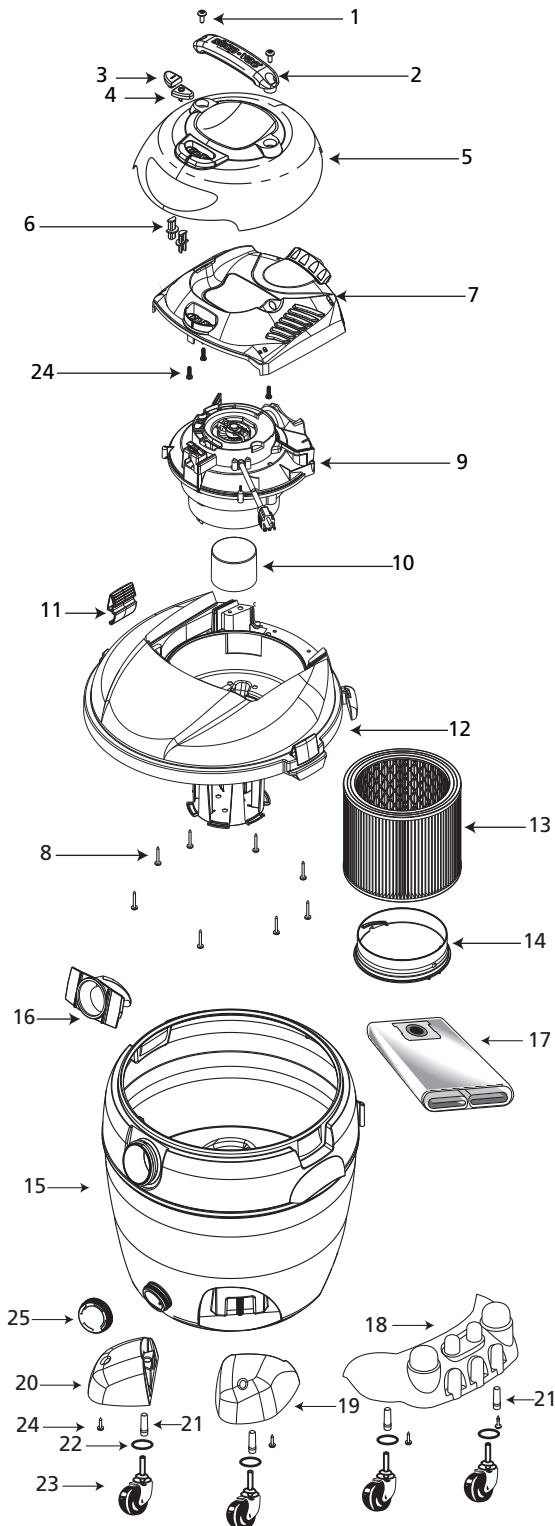

ITEM	DESCRIPTION	PART NO.
1	Screw 1/4 x 3/4 Trilobe T30 HD	1516499
2	Handle	7444400
3	Switch Button - I	7414200
4	Switch Button - O	7414210
5	Outer Motor Cover Assembly	1944137
6	Switch Button Extension	7414250
7	Inner Motor Cover	3743052
8	Screw 10 x 3/4" Trilobe, Twin Lead	1517699
9	Power Unit Assembly	8135597
10	Float	3545000
11	Lid Latch	7444500
12	Lid Cage & Latch Assembly	1944210
13	Cartridge Filter	90304
14	Filter Retainer	3008000
15	Tank Assembly	7365597
16	Inlet Deflector	7413100
17	Collection Bag	90663
18	Rear Caster Dolly	7431235
19	Casterfoot A	7431330
20	Casterfoot B	7431350
21	Retainer	8565700
22	Flatwasher	0704399
23	Caster	6773900
24	Screw 10 x 3/4" SL Hex Head	1503999
25	Drain Cover	7446800

* Replacement parts may differ from original equipment.

FOUR-YEAR HOME USE WARRANTY

Your Shop-Vac® vacuum cleaner is warranted in normal household use, in accordance with the User Manual, against original defects in material and workmanship for a period of four years from date of purchase. Should this product be used for commercial or rental use, a 90 day limited warranty will apply. Shop-Vac Corporation warrants placing this vacuum cleaner in correct operating condition, by repair or parts replacement, during the warranty period, without charge. This warranty does not cover accessories. Use of non-recommended filters and/or accessories may void the manufacturer's warranty.

For product service contact Shop-Vac Corporation, Customer Service, at (570) 326-3557 or go to www.shopvac.com/support. Shop-Vac® assumes no responsibility for damage or faulty performance caused by misuse or careless handling, or where repairs or modifications have been made or attempted by others. Proof of purchase date is required. This warranty gives you specific legal rights, and you may also have other rights, which vary from state to state. This warranty is void outside of the United States.